

**NEW**



0.8mm pitch bay connector

CONNECTOR

MB-0089-3

July 2006

## PM1 Series

**RoHS Compliant**

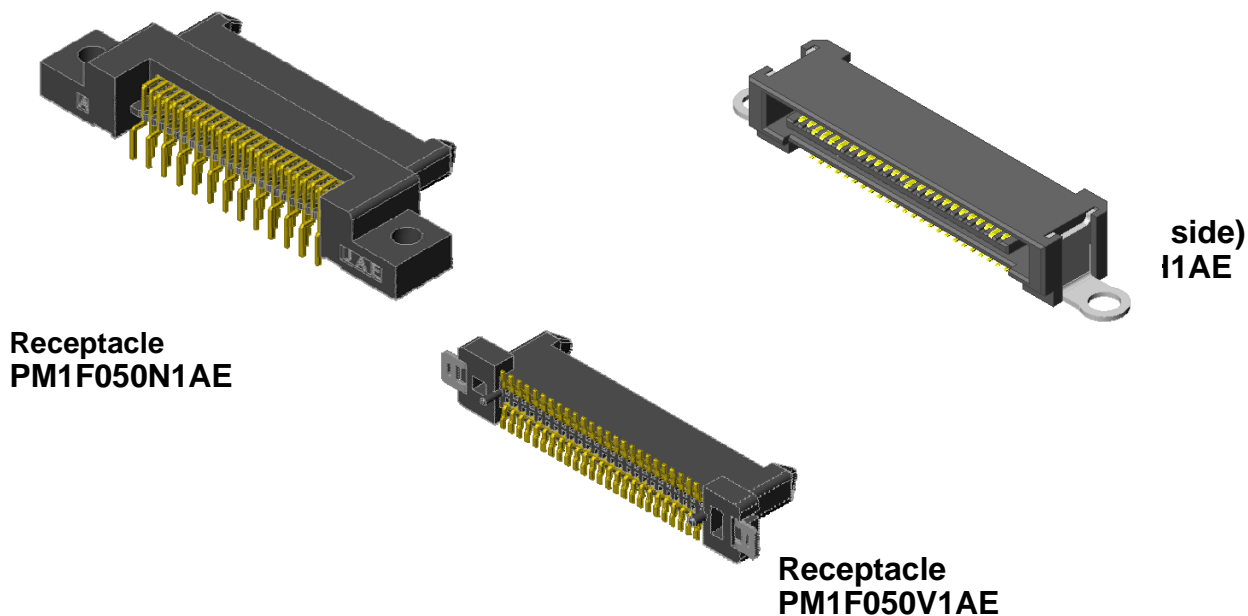

PM1 series is a bay connector compatible with optical drive 9.5mm thick.

### Features

- Connector height 5.4mm, low profile board to board bay connector.
- Plug side (PM1M050H1AE) with 2-step contact length-insertion structure.  
Compatible to 2-step contact length-insertion structure (step difference: 0.4mm) by 2 contact types (contact length 3.1mm and 2.7mm)
- Superior displacement error absorption structure  
Insertion guide absorbs the displacement caused by insertion and removal from drive.
- Lifetime 7000 times, achieved
- Plug side (PM1M050H1AE) can be mounted to board in common with KX15-50KLDP.  
(There is no mating compatibility between PM1series and KX14/15 series connectors)

### General Specifications

- No. of contacts: 50 pos.
- Contact resistance: 70m ohm max.
- Dielectric withstanding voltage:  
AC 250 Vr.m.s (per minute)
- Contact pitch: 0.8mm
- Operating temperature: -40 to+85 Deg. C
- Rated current: 0.5A per contact
- Insulation resistance: 100M ohm min.
- Life time: 7000 times
- Rated voltage: AC125V.r.m.s

Materials and Finishes
------------------------

Componets	Materials	Finishes
Base Insulator	LCP filled with heat-resistant plastic glass	None(UL94V-0), Black
Contact	Copper alloy	Contact area: Au plating Terminal area: Sn plating over Ni
Reinforcement	Copper alloy	Sn type plating

Ordering Information

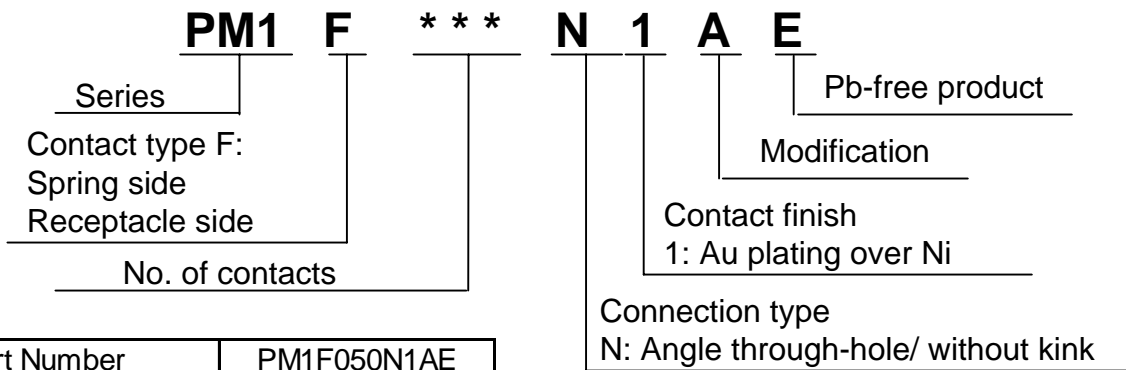

Part Number	PM1F050N1AE
Drawing Number	SJ101417

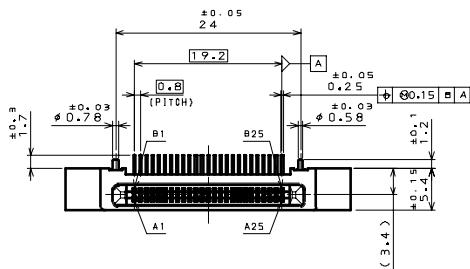

Drawing when mated  
(for reference)

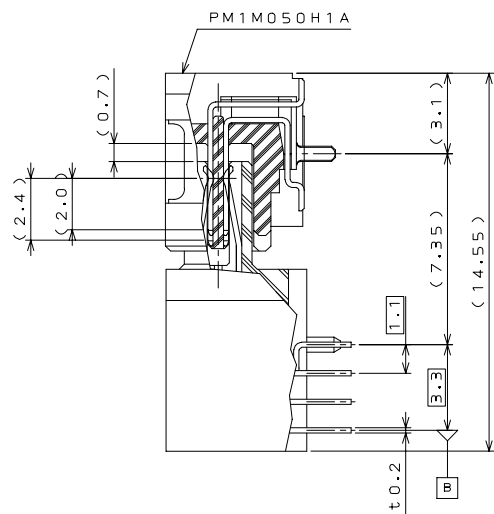
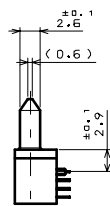
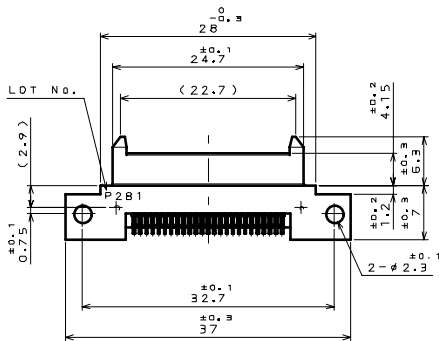

Applicable dimension of board  
(for reference)

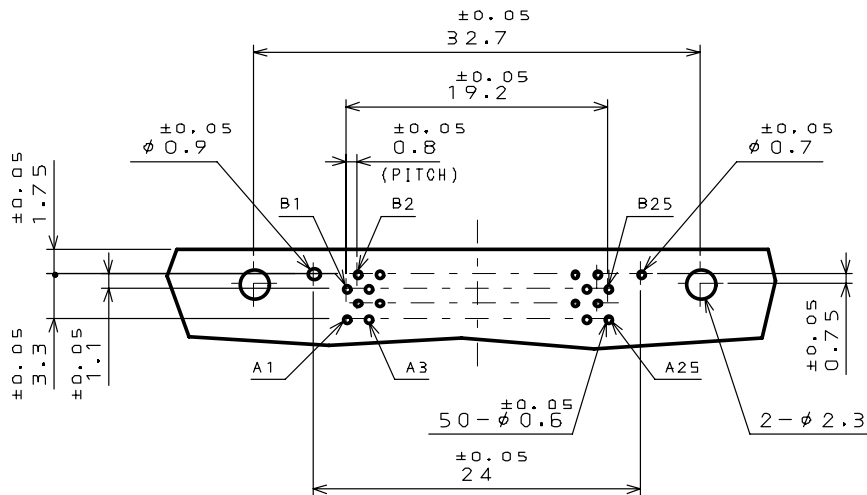

APPLICABLE P.C.B. DIMENSION (REF.)

Ordering Information

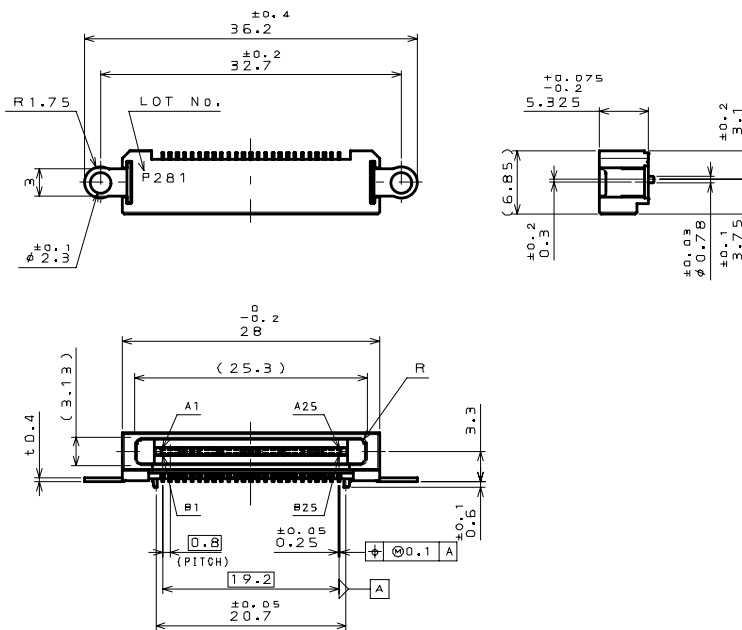
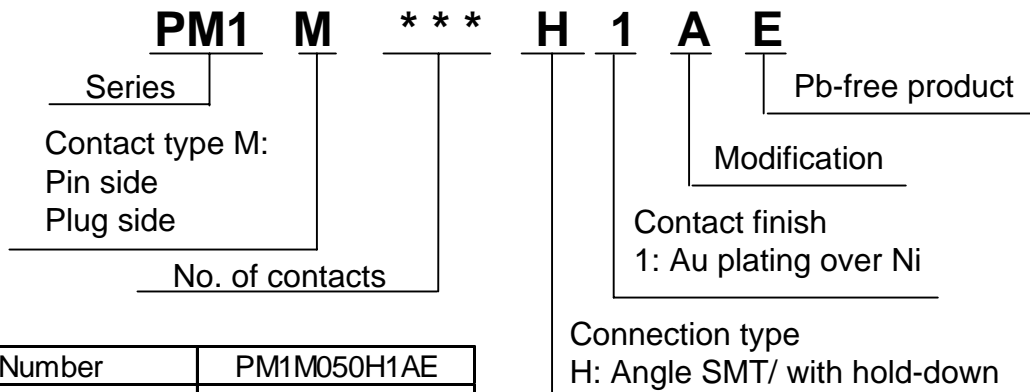

Applicable dimension of board  
(for reference)

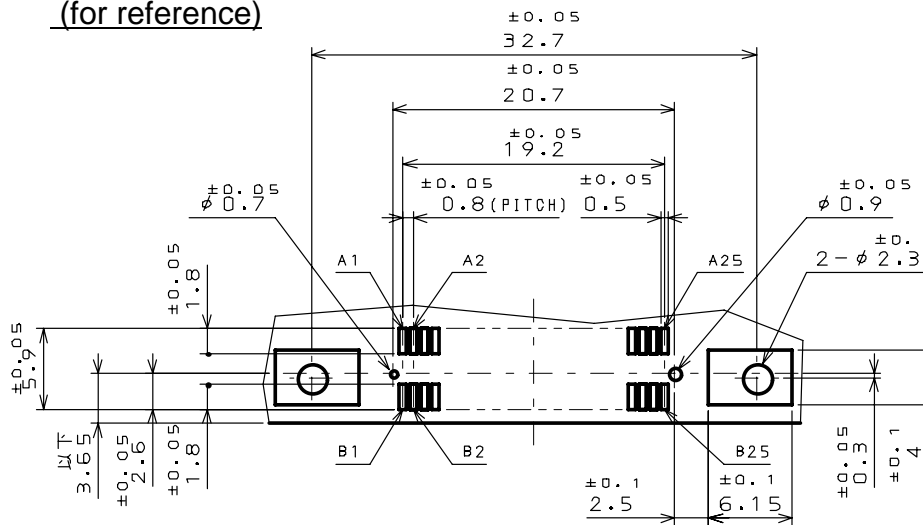

APPLICABLE P.C.B. DIMENSION (REF.)

Note1) An embossed tape reel contains 1,000 pieces.  
Please contact us for details of embossed tape specifications.

Ordering Information

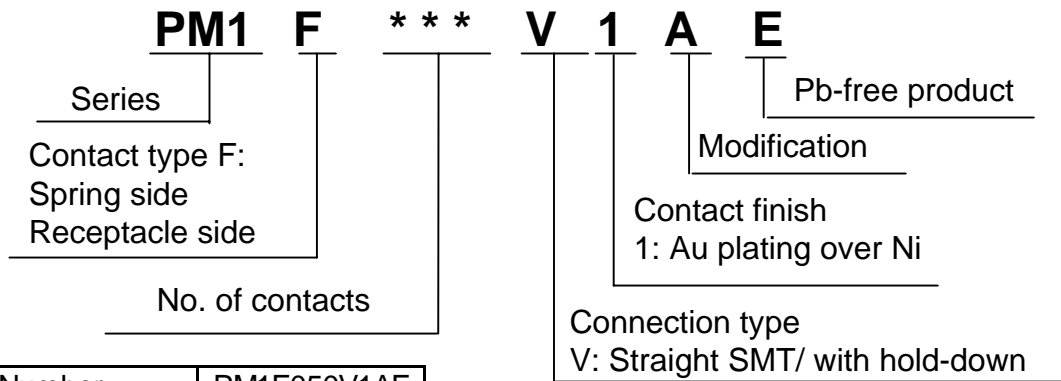

Part Number	PM1F050V1AE
Drawing Number	SJ101423

Drawing when mated  
(for reference)

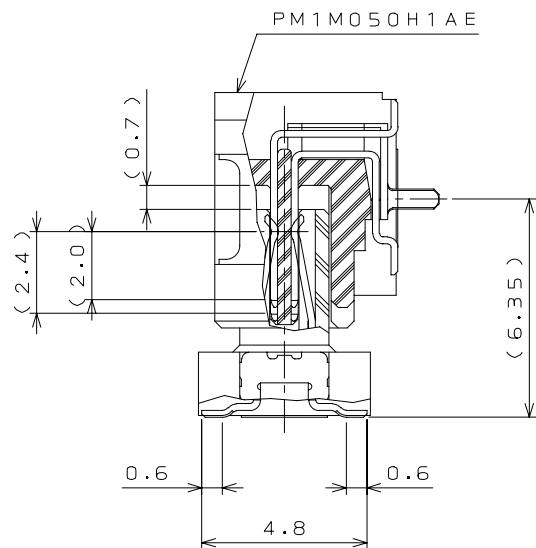
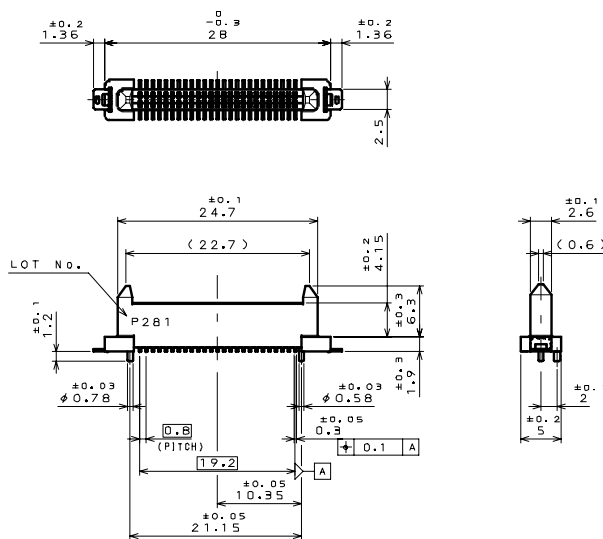

Applicable dimension of board  
(for reference)

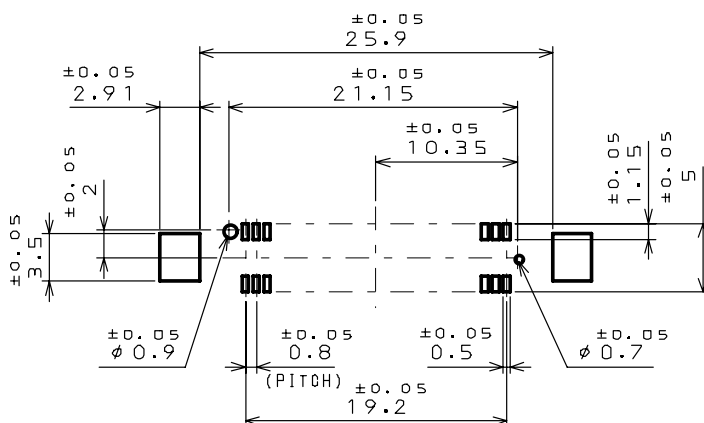

APPLICABLE P.C.B. DIMENSION(REF.)

**Notice:** Products shown in this leaflet are made for the applications listed below. However, if the above-mentioned products are to be used in aerospace devices, marine cable-connection devices, atomic power control systems, medical equipment for life-support systems, or any other specific application requiring extremely high reliability, please contact JAE for further information.

Recommended applications: Computers, Office machines, Measuring devices, Telecommunication devices (Terminals, Mobile devices), AV devices, Household applications, FA devices, etc.

Japan Aviation Electronics Industry, Limited

Product Marketing Division  
Aobadai Building, 3-1-19, Aobadai, Meguro-ku, Tokyo 153-8539  
Phone: +81-3-3780-2787 FAX: +81-3-3780-2946